

Thermo Fisher Scientific provides reliable real time oxygen scavenger monitoring – to ensure optimum efficiency throughout your plant's water and steam loop. Accurate results with rapid response – our monitor is your best defense for controlling corrosion with performance you can trust!

Thermo Scientific Orion 2118XP Oxygen Scavenger Monitor



Superior performance and ease of operation

As the demand for electricity expands, the quality and consistency of each plant's operation is essential for efficient power generation. To maintain high purity water standards for peak production, accurate and reliable monitoring is critical.

The NEW Thermo Scientific Orion 2118XP oxygen scavenger monitor offers unmatched results for the control and optimization of oxygen scavenger systems. Control spending and protect your system using the Orion 2118XP - the perfect balance of performance and ease of use.

The Orion 2118XP is ideally suited to monitor oxygen control in feedwater, boiler water, deaerator inlet/outlet, condensate discharge and economizer inlet. Ensure a sufficient amount of oxygen scavenger without upsetting system pH or additional expense.

The Orion 2118XP provides stable, drift-free measurements with minimal maintenance and less frequent calibrations.

Advantages:

- Designed for versatility, our unique chemistry measures most oxygen scavengers with only a change in the standard
- Accurate and precise oxygen scavenger control maintains proper feed levels with confidence
- Repeatable and verifiable correlation of hydrazine readings to ELIMIN-OX® concentration using a proprietary iodide reaction for the highest level of performance available
- Easy to operate and calibrate with step-by-step calibration prompts that ensure a successful calibration the first time and every time
- User selectable calibration modes offer the most precise measurements, using online two point calibration or use the off-line calibration to match your lab results and maximize uptime



Markets

- Power
- Pulp and Paper
- Semiconductor

Applications:

- Boiler Feedwater
- Hydrazine
- ELIMIN-OX®
- DEHA and other Carbohydrazides

Benefits

- Oxygen scavenger detection of hydrazine: 0 ppb to 200 ppb, ELIMIN-OX®: 0 ppb to 1000 ppb with the highest accuracy and precision available
- Continuous online measurement ensures real time information for optimum control of the oxygen scavenger feed pump without excessive operating costs
- Extremely easy to use while maximizing uptime - simple step-by-step scrolling instruction for setup, calibration, operation and diagnostics menus
- Measurements at a glance from any distance for even the lowest light conditions using the large operator friendly visible backlit display
- Fastest most stable measurements, limiting unnecessary calibration cycles due to drift with superior Orion iodide electrode technology
- Minimize operator time and maintenance without use of complicated moving parts or pumps that often require frequent attention and expensive spare part expenditures
- Extend reagent consumption up to 2 months using our uniquely simple reagent addition design to condition the sample pH and suppress interfering ions for optimal measurement performance
- Advanced user interface with detailed calibration, measurement and diagnostic logs for early diagnostic and action level notification, configurable for your facilities desired level of performance- all password protected if preferred
- Simple and fast user selectable calibration modes for precise 2 point calibration for ultimate accuracy or off-line calibration for lab correlation to have your system back online with security and confidence
- Easy installation has your plant up and running in minutes - the Orion 2118XP is retrofittable to the Orion 1818A0 panel mounting footprint

Dimensions

Thermo Scientific Orion 2118XP installation dimensions shown without optional protective enclosure.

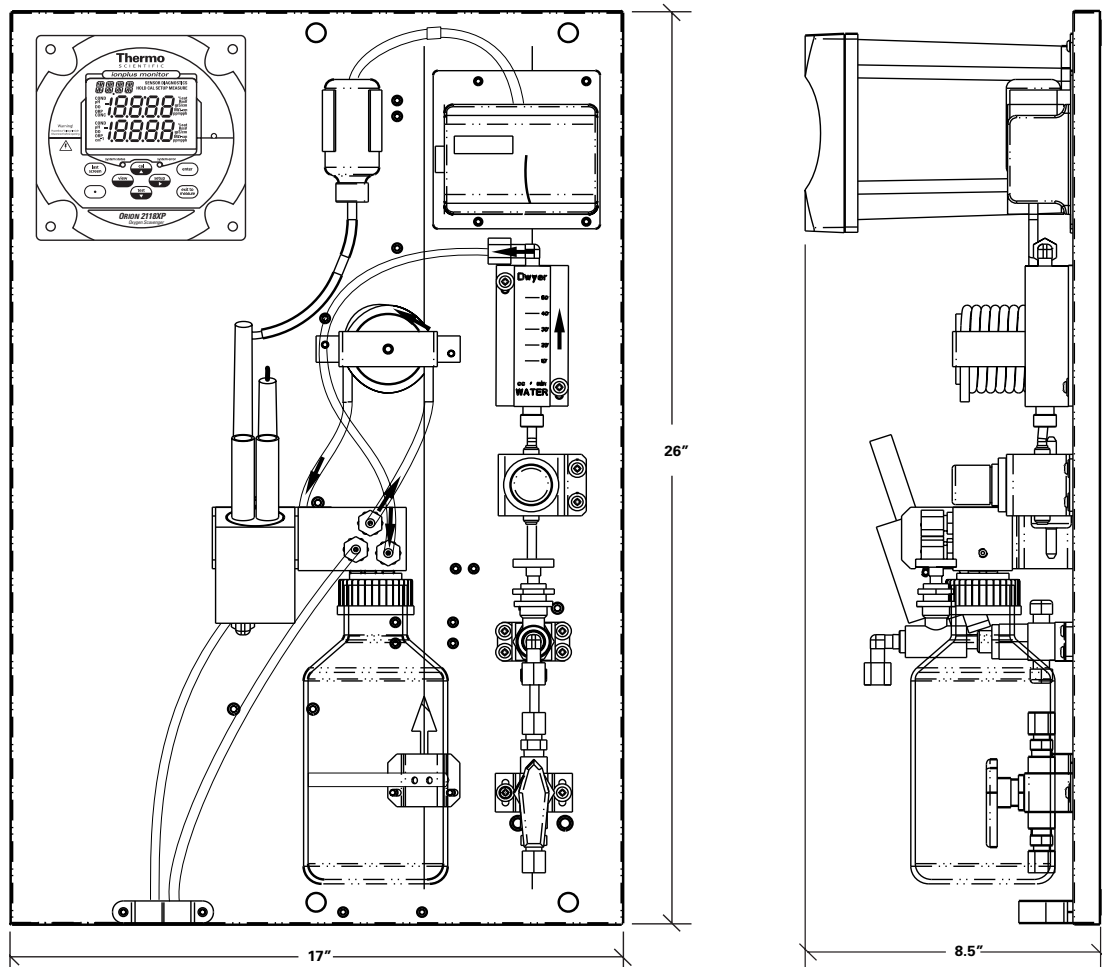



Thermo Scientific Orion 2118XP Oxygen Scavenger Monitor

Specific Ion Measurements	Range: Hydrazine: 0 ppb - 200 ppb ELIMIN-OX®: 0 ppb - 1000 ppb
	Resolution: 2, 3 or 4 digits
	Accuracy (with DYN cal): Oxygen Scavenger: ± 5% or 2 ppb ELIMIN-OX®: ±5 % or 30 ppb
	Reagent: Iodide Reagent
Response Time	Reach 90% of reading within 1 minute of injecting a standard solution
Units Displayed	ppb, ppm (auto ranging), mV, temperature
mV Measurement	Range: ± 1999.9 mV
	Resolution: 0.1 mV
	Relative accuracy: ± (0.5 mV + 0.1%)
Temperature Measurement	Range: - 10 to 120 °C
	Resolution: 0.1 °C
	Relative accuracy: ± 0.5 °C
	Continuous temperature readings: YES
	ATC probe connection detection: YES
Specific Ion Calibrations	Dynamic Dilution calibration: YES
	Dynamic Dilution calibration points: 2 points
	Offline calibration: YES
	Offline calibration points: 1 point
	Pre-programmed standard values: YES
	Custom programmed standard values: YES
Sample Conditions	Temperature: 5 to 45 °C
	Total alkalinity: less than 50 ppm CaCO ₃
	Inlet pressure: 8 to 100 psig
	Flow rate: 40 mL/min nominal set by pressure regulator
	Sample inlet: 1/4" NPTF tube fitting
	Sample drain: 3/4" NPT male
	Grab sampler supported: YES
Display	Custom backlit LCD with temperature, concentration, mV, error codes, menu driven prompts
Inputs	ATC: 2 x NTC 30K
	Specific ion input & reference: Potentiometric

Outputs	Analog output: Galvanically isolated
	Number of analog outputs: 2, one dedicated to oxygen scavenger, one to temperature; shared ground
	Output selections: 0 - 20 mA or 4 - 20 mA
	Programmable range: YES
	Log & linear output options: YES, user selectable
	Alarm outputs: 3
	Number of relay outputs: 3
	Maximum relay load: 250 VAC, 5 A, 30 VDC
	Minimum value alarm: YES
	Maximum value alarm: YES
	Error alarm: YES
	Calibration/offline alarm: YES
Programmable min & max values: YES	
Physical Size	Electronics: 144 x 144 x 186 mm
	Entire system: 65 x 45 x 27 cm (26" x 17" x 11") Fits on 1818A0 panel mounting footprint.
Power	Input: 85-132 or 170-264 VAC
Software Features	Self-test & diagnostics: YES
	Real time clock: YES
	Meter serial number: YES
	Password protection: YES
	Programmable alarms: High, low, error, calibration/offline
	Reset function: YES
	Startup reset: YES
	Hardware calibration function: YES
Non-volatile memory: YES	
Battery backup: YES	
Expansion bus: Serial communication & power	
Waterproof enclosure: IP66 & NEMA 4X	
Regulatory and Safety	CE, CSA, UL, FCC Class A limits
Environmental Operating Conditions	Ambient operating temperature: 5 to 45 °C
	Relative humidity: 5 to 95% non-condensing
	Storage temperature: - 20 to 60 °C
	Storage humidity: 5 % to 95 %, non-condensing
Case Material	Valox 364
Shock and Vibration	Vibration, shipping/handling: 0 - 60 Hz @ 1 G Load
	Shock, drop test in packaging: 36" on all sides and corners

Thermo Scientific Orion 2118XP Oxygen Scavenger Monitor

- **Global support**– with experience that comes from supporting our calcium hardness customers for over 35 years throughout the world, our water quality specialists and customer support teams offer a quick, thorough and professional response to any problem encountered.

- **Focus on user benefits**– we work closely with you to define your needs, and ensure you are using the monitor in a way that improves your bottom line.

For more information, contact your local water quality specialists, call 1-800-225-1480 or visit www.thermo.com/water.

Cat. No.	Oxygen Scavenger Monitor Packages
2118XPEN	Oxygen Scavenger Monitor with Protective Enclosure Package – Includes oxygen scavenger monitor with protective enclosure, iodide sensing electrode (100022), reference electrode (100056), ATC probe (2100TP), CD user guide and options kit
2118XP	Oxygen Scavenger Monitor Instrument Only Package – Includes oxygen scavenger monitor, iodide sensing electrode (100022), reference electrode (100056), ATC probe (2100TP), CD user guide and options kit

Cat. No.	Reagent Kits and Accessories
211850XP	Oxygen Scavenger Consumables Kit – for one year operation, includes (6) iodide reagent (6 x 1 L bottles) with (6) 6 ft length diffusion tubing assemblies with O-rings (2 x 181811), reagent bottle adapter (2118RBA), (1) 100 ppm hydrazine standard solution, pint (151810), (1) iodide sensing electrode (100022), (1) reference electrode (100056), (5) x 2 oz bottles reference filling solution (181073), (1) O-ring kit (2118OK), (1) restriction tube assembly, (2100RT), (2) 60 micron inlet filters and (1) filter gasket (181127)
211850XPF*	Reagent-less Oxygen Scavenger Consumables Kit – for one year operation, includes (6) empty bottles for use with iodide reagent (6 x 1 L bottles) with (6) 6 ft length diffusion tubing assemblies with O-rings, reagent bottle adapter (2118RBA), (1) 100 ppm hydrazine standard solution, pint (151810), (1) iodide sensing electrode (100022), (1) reference electrode (100056), (5) x 2 oz bottles reference filling solution (181073), (1) O-ring kit (2118OK), (1) restriction tube assembly, (2100RT), (2) 60 micron inlet filters and (1) filter gasket (181127)
181811	Iodide Reagent – for 6 months operation, includes (3) x 1 L bottles of iodide reagent and (3) 6 ft length diffusion tube assembly with O-rings (15 small for use on reagent bottle adapter connection barbs and 3 large for reagent bottle cap)
181860	Diffusion Tubing Kit – (3) 6 ft diffusion tubing assembly with O-rings

Cat. No.	Iodide Electrodes and Accessories
2118XPEK	Iodide Electrode Kit – includes (1) iodide electrode (100022) and (1) reference electrode (100056)
100022	Iodide Sensing Electrode – with screw cap, for use with 2118XP
100056	Iodide Reference Electrode – with screw cap, for use with 2118XP, includes reference electrode filling solution (181073)
181073	Reference Electrode Filling Solution – (5) x 2 oz bottles for use with reference electrode (100056), 3 month supply when used with pressurized reference assembly
2100TP	2100 Series Automatic Temperature Probe – with ground (30 kΩ), for use with 2118XP
2001XT	2100 Series Automatic Temperature Probe – with 10 meter extension cable and ground (30 kΩ), for use with 2118XP

Cat. No.	Iodide Electrodes and Accessories (cont'd)
21003M	Extension Cables – (2) 3 meter cables, for 100022 and 100056 electrodes
2118XPCAL	Calibration Kit with Carrying Case – includes (1) dynamic calibrator (21DC00), (1) 100 ppm hydrazine standard solution, pint (151810), and syringe kit for use with dynamic calibrator (180096)
151810	Hydrazine Standard Solution – includes (1) 475 mL bottle of 100 ppm hydrazine standard solution

Cat. No.	Field Replaceable Units
2100EN	2100 series enclosure for use with 2118XP
2118FP	Fluidics panel assembly only
2118XPEP	2118XP electronics faceplate
2100NV	Inlet valve assembly
2100BV	Needle valve assembly
2100RG	Regulator assembly
2100FM	Flow meter assembly
2100RT	Restrictor tube assembly
2118RBA	Reagent bottle adapter assembly with diffusion tube assembly
2100PA	Air pump assembly
2100AF	Air filter
2100TG	Tygon tubing (4 ft)
2100PS	Power supply assembly
2100FK115	Fuse kit assembly 115 V
2100FK230	Fuse kit assembly 230 V
2118PN	Pressurizing needle assembly
2118MC	Mixing coil-tubing spool assembly
2118MV	Micro-valve assembly, for calibration standard injection port
2118CV	Calibration valve assembly
2118CB	Fluid connector block assembly, with thumb screw and injection port
2118FC	Flow cell assembly with electrode holder, mounting bracket and O-rings
2118OK	O-ring kit- includes O-rings for reagent bottle and cap, micro-valve, and electrode holder
181170	(2) Inlet sample filters and gaskets
2118XPSK	Service Kit – includes (1) electronic faceplate (2118XPEP), (1) air pump assembly (2100PA), (1) regulator assembly (2100RG), (2) electrode cable with gland assemblies for sensing and reference electrodes, (1) power supply assembly (2100PS), and (1) fuse kit assembly (2100FK115 and 2100FK230)