

INFRARED GAS ANALYZER (LOW-CONCENTRATION MEASUREMENT TYPE)

DATA SHEET

ZPG

This gas analyzer (ZPG) is capable of measuring the concentration of NO, SO₂, CO₂, CO and O₂ components in sample gas. NO, SO₂, CO₂, CO are measured by non-dispersion infrared method (NDIR), while O₂ is measured by fuel cell or paramagnetic and zirconia method. Through use of the sample switching system, ZPG is capable of canceling drift in the zero point of the measurable component by NDIR. Optimum use as an analyzer unit of a measurement system for gas separation process and atmospheric environment measurement and combustion exhaust gas from refuse incinerators and boilers, or gas from various industrial furnaces.

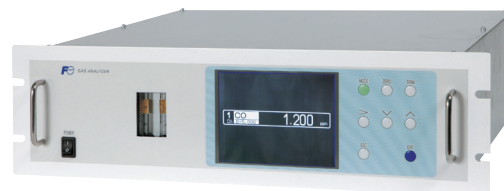

FEATURES

- 1. High sensitivity**
Equipped with the newest upgraded mass flow sensor. Capable of 0-5ppm measuring range with a newly designed measurement unit.
- 2. Excellent stability**
Due to adoption of sample switching method (note1). It is capable of canceling drift in the zero point of measurable component.
- 3. Easy maintenance**
Single beam design simplifies maintenance and minimizes maintenance costs compared with double beam or similarly equipped GFC based system.
- 4. Small and light**
The size is small 133x483x382mm (HxWxD) and light (11kg). It is capable of measuring one of NO, SO₂, CO₂, CO components by NDIR and simultaneously measuring O₂ by O₂ analyzer.
- 5. Extensive functions**
Various optional functions are available such as auto calibration control, atmospheric pressure correction, high and low concentration alarm, remote range switch, and range identification signal, etc.
note1) Excellent long term stability due to sample gas and reference gas flowed alternately to the measurement unit.

SPECIFICATIONS

Standard Specifications

Principle of measurement:

- NO, SO₂, CO₂, CO;
Non-dispersion infrared-ray absorption method (NDIR method)
- Single light source and single beams (single beam system)

O₂ ; Fuel cell O₂ analyzer (built in) or paramagnetic O₂ analyzer (built-in) or zirconia O₂ analyzer (externally installed TYPE: ZFK7)

Measurable gas components and measuring range:

	Minimum range	Maximum range
NO	0 - 10ppm	0 - 100ppm
SO ₂	0 - 10ppm	0 - 100ppm
CO ₂	0 - 5ppm	0 - 50ppm
CO	0 - 5ppm	0 - 50ppm
O ₂ (built in fuel cell)	0 - 10vol%	0 - 25vol%
O ₂ (built-in Paramagnetic)	0 - 5vol%	0 - 100vol%
O ₂ (External Zirconia)	0 - 5vol%	0 - 25vol%

- Max. 2 components measurement including O₂.
- Measuring range ratio max. 1:10 (except O₂)
- Measuring ranges are changeable between the specified minimum and maximum range
Settable one range or two ranges
* In measurement range, low range is called first range, high range is called second range.

Measured value indication:

- Digital indication in 4 digits (LCD panel with LED back light)
- Instantaneous value of each component
- Instantaneous value after O₂ correction (only in NO, SO₂, CO measurement with O₂)
- Average value after O₂ correction (only in NO, SO₂, CO measurement with O₂)
- O₂ average value

Analog output signals:

4 to 20mA DC or 0 to 1V DC,
isolated internally from circuit and ground.
Output lines are non-isolated each other.;
4 outputs max.

Allowable load 550Ω for 4 to 20mA DC

Allowable load 100kΩ for 0 to 1V DC

* Refer to Table1 for the channel No. of
displayed values and analog output
signals.

Analog input signal:

For signal input from externally installed
O₂ analyzer.

Signal requirement;

(1) Signal from Fuji's Zirconia O₂ analyzer
(TYPE: ZFK7)

(2) 0 to 1V DC from an O₂ analyzer
Input section is not isolated. This fea-
ture is effective when an O₂ analyzer
is not built in.

* Externally installed O₂ analyzer should
be purchased separately.

Digital output: (Option)

1c contact (24V DC/1A, resistive load)
max.10 outputs

Instrument error, calibration error,
range identification, auto calibration
status, solenoid valve drive for auto
calibration, High/Low limit alarm con-
tact output

* All relay contacts are isolated mutually
and from the internal circuit.

Digital input: (Option)

Voltage contact (supply 12-24VDC (15mA
Max.)) Max.6 inputs

Remote range change over, auto cali-
bration remote start, remote hold,
average value reset, Isolated from
the internal circuit with photocoupler.

Power supply: Voltage rating ; 100V to 240V AC
Allowable range ; 85V to 264V AC
Frequency ; 50Hz/60Hz
Power consumption ; 100VA max.

Operation conditions:

Ambient temperature;
-5°C to 45°C

Ambient humidity ; 90% RH max.,
non-condensing

Storage conditions:

Ambient temperature; -20°C to 60°C

Ambient humidity ; 100% RH max.,
non-condensing

Dimensions (H × W × D):

133 × 483 × 382mm

Mass: 11 kg max.

Finish color: Front panel; Cool gray (PANTON 1C-F)

Enclosure: Steel casing, for indoor use

Material of gas-contacting parts:

Gas inlet/outlet; SUS304

Sample cell; SUS304, chloroprene rubber

Infrared-ray transmitting window; CaF₂

Paramagnetic O₂ analyzer cell; SUS316

Fuel cell O₂ analyzer cell; ABS resin

Internal piping; Toaron, Teflon, Polypropylene

Solenoid valve; fluoro-rubber

Gas inlet/outlet: Rc1/4 or NPT1/4 internal thread

Purge gas flow rate: 1L/min (when required)

Life time of fuel cell O₂ analyzer: 2 years

Standard Functions**Output signal holding:**

Output signals are held unchanged during
manual and auto calibrations by activation
of holding (turning "ON" its setting).

The values held are those just before start
calibration mode or setting value.

Usage is selectable.

Indication of instantaneous values will not
be held.

Switch ranges: The switch ranges function is available in
manual, auto, and remote modes. Only
preset switch method is effective.

Manual: Allows range to switch by key opera-
tion.

Auto: Automatically switched from first range to
second range when the measured value
exceeds 90%FS of first range.

Automatically switched from second range
to first range when the measured value
drops to 80% or less first range.

Remote: Voltage contact input (for measurable
(Option) components)

Allows range to switch via an external
signal when remote range switch input
is received.

When the contact input terminals for
each component are input voltage, the
first range is selected, and it is switched
to the second range when the terminals
are open.

* These switch range value are settable between
the first range and second range values (low/high
range values).

Optional Functions**Remote output holding:**

Output signal is held at the last value or
preset value by voltage input to the remote
output holding input terminals.

Holding is maintained while voltage is
input to the terminals. Indication of in-
stantaneous values are not held.

Range identification signal:

The present measuring range is identified
by a contact position.

The contact output terminals close for
each component when the first range
is selected, and open when the second
range is selected.

Auto calibration:

Auto calibration is carried out periodically
at the preset cycle.

When a standard gas cylinder for calibration
and a solenoid valve for opening/closing
the gas flow line are prepared externally
by the customer, calibration will be carried
out with the solenoid valve drive contacts
for zero calibration and each span calibra-
tion turned on/off sequentially at the set
auto calibration timing.

Auto calibration cycle setting:

Auto calibration cycle is set.
Setting is variable within 1 to 99 hours (in increments of 1 hour) or 1 to 40 days (in increments of 1 day).

Gas flow time setting:

The time for flowing each calibration gas in auto calibration is set.
Settable within 60 to 900 seconds (in increments of 1 second)

Auto calibration remote start:

Auto calibration starts by opening the auto calibration remote start input terminal after short circuiting for 1.5 sec or longer.
Auto calibration starts when contacts open.

Auto zero calibration:

Auto zero calibration is carried out periodically at the preset cycle.
This cycle is independent from "Auto calibration" cycle.
When zero calibration gas and solenoid valve for opening/closing the calibration gas flow line are prepared externally by the customer, zero calibration will be carried out at the set auto zero calibration timing.

Auto zero calibration cycle setting:

Auto zero calibration cycle is set.
Setting is variable within 1 to 99 hours (in increments of 1 hour) or 1 to 40 days (in increments of 1 day)

Gas flow time setting:

The timing for flowing zero gas in auto zero calibration is set.
Settable within 60 to 900 seconds (in increments of 1 second)

High/low limit alarm:

Alarm contact output turns on when measurement value reaches the preset high or low limit alarm value.
Contacts close when the instantaneous value of each channel exceeds the high alarm limit value or falls below the low alarm limit value.

Instrument error contact output:

Contacts turn on at occurrence of analyzer error No. 1, 2, 3 or 10.

Calibration error contact output:

Contacts turn on at occurrence of manual or auto calibration error (any of errors No. 4 to 9).

Auto calibration status contact outputs:

Contacts turn on during auto calibration.

O₂ correction: Correction of measured NO, SO₂ and CO gas concentrations into values at reference O₂ concentration.

Correction formula:

$$C = \frac{21-O_n}{21-O_s} \times C_s$$

C : Sample gas concentration after O₂ correction

C_s : Measured concentration of sample gas

O_s : Measured O₂ concentration (Limit setting: 1 to 20% O₂)

O_n : Reference O₂ concentration (value changeable by setting.0 to 19% O₂)

Average value after O₂ correction and O₂ average value calculation:

The result of O₂ correction or instantaneous O₂ value can be output as an average value over the preset period of time.
Moving average method is used. Sampling interval is 30 seconds.
(Output is updated every 30 seconds. Update is the averaged value of the most recent elapsed averaging time period.)
Averaging time period is settable within 1 to 59 minutes (in increments of 1 minute) or 1 to 4 hours (in increments of 1 hour).

Average value resetting:

The above-mentioned output of average value is started from the initial state by opening the average value resetting input terminals after short circuiting for 1.5 sec or longer.
Output is reset by input voltage and restarted by opening the terminal circuit.

Communication function:

RS-485 (9pins D-sub connector)
Half-duplex bit serial
Start-stop synchronization
Modbus RTU™ protocol
Contents : Read/Write parameters
Read measurement concentration and instrument status
Remark : When connecting via RS-232C interface, an RS-232C ↔ RS-485 converter should be used.

Atmospheric pressure correction:

Measure atmospheric pressure and calculate compensation (for use, be sure to relieve the exhaust gas from analyzer to the atmosphere)

After atmospheric pressure correction;

Zero point : No influenced
Span point: The change is 0.5% measured value or less relating to the change of the atmospheric pressure 1% .

Correction range: 700hPa-1050hPa

Performance

Repeatability:	±0.5% of full scale
Linearity:	±1% of full scale prior to atmospheric pressure correction (option)
Zero drift:	±0.5% of full scale/week (measurable component of NDIR) ±2.0% of full scale/week (O ₂ analyzer)
Span drift:	±2.0% of full scale/week
Response time (T ₉₀):	30 seconds or better Response interval may be changed de- pending on timing of the switching gas by sample switching operation. (Td=5-20 seconds)

Interference from other gases:

Sample switching design effectively minimizes interference. But it may occur depending on component gas and its concentration.
Preprocessing can further decrease influence in this case.
Contact manufacturer for application specific advice.

EC Directive Compliance

The product conforms to the requirements of the Low Voltage Directive 2006/95/EC and EMC directive 89/336/EEC (as amended by Directive 92/31/EEC), both as amended by Directive 93/68/EEC.

It conforms to following standards for product safety and electromagnetic compatibility ;

EN61010-1:2010, EN62311:2008

Safety requirements for electrical equipment for measurement, control and laboratory use.

"Installation Category II"

"Pollution Degree 2"

EN61326-1:2006, EN61326-2-3:2006,

EN61000-3-2:2006, A1:2009, A2:2009

EN61000-3-3:2008

Electrical equipment for measurement, control and laboratory use — EMC requirements.

CE

Requirements for Sample Gas

Flow rate:	1.0 ±0.2L / min
Temperature:	0 to 50°C
Pressure:	10 kPa or less (Gas outlet side should be open to the atmospheric air.)
Dust:	100 µg/Nm ³ or less in particle size of 0.3 µm or smaller
Mist:	Unallowable
Moisture:	For CO, NO, SO ₂ measurement: less than 2°C saturation point. For CO ₂ measurement: less than -30°C saturation point (with comparable moistive levels in sample and reference gases).

Corrosive component:

1 ppm or less

Standard gas for calibration:

Zero gas ; Dry N₂

Span gas ; Each sample gas having concentration 90 to 100% of its measuring range (recommended).

In case a zirconia O₂ analyzer is installed externally and calibration is carried out on the same calibration gas line:

Zero gas ; Dry air or atmospheric air (Do not use with CO₂ measurement)

Span gas ; For other than O₂ measurement, each sample gas having concentration 90 to 100% of its measuring range
For O₂ measurement, O₂ gas of 1 to 2 vol%/remains N₂ gas

Reference gas for sample switching:

NO, SO₂, CO measurement;

When sample gas contains moisture, N₂ which contains moisture equivalent of moisture of the sample gas, or Air. When sample gas does not contain moisture, Dry N₂ or Dry air.

CO₂ measurement;

N₂ without CO₂ and moisture. (over 99.999999vol%)

(Do not contain the component to be measured more than 0.1%FS of the minimum measuring range.

Please refer to the "component eliminator" described later and use the component eliminator to meet the above condition if necessary.)

Purge gas:

When base gas is H₂, and any of the measured component, Please make sure to purge the inside of the instrument with N₂ gas or Air.

Installation Requirements

- Indoor use (Select a place where the equipment does not receive direct sunlight, draft/rain or radiation from hot substances. If such a place cannot be found, a roof or cover should be prepared for protection.)
- Avoid a place where unit receives heavy vibration
- Select a place where atmospheric air is clean

Principle diagram of NDIR type measurement (For NO, SO₂, CO₂, CO)

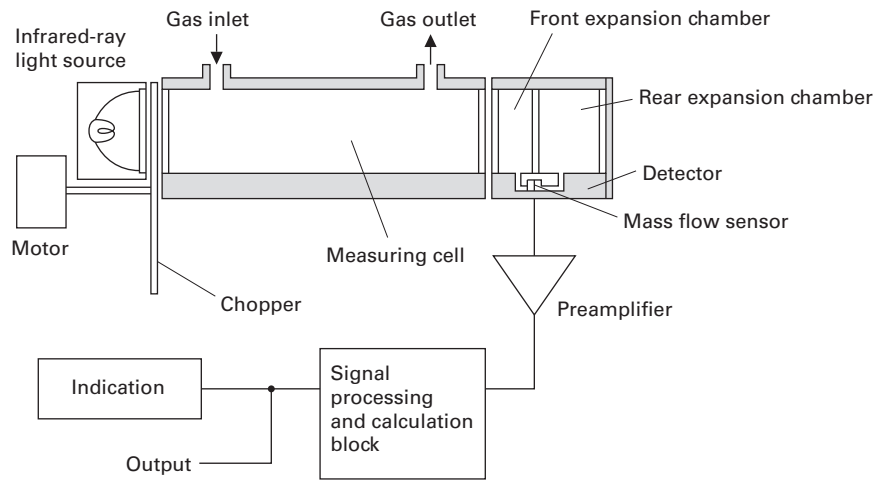

Principle diagram of fuel cell type measurement (For O₂)

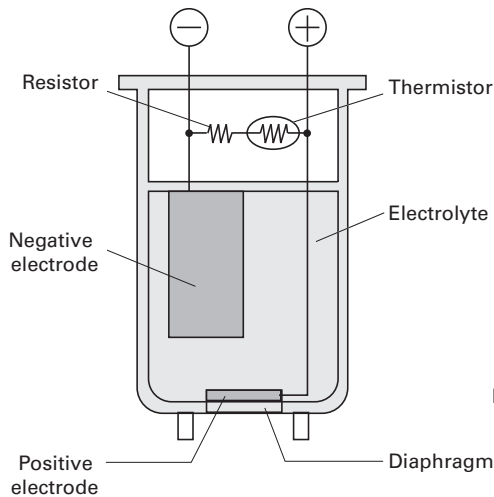

Principle diagram of paramagnetic type measurement (For O₂)

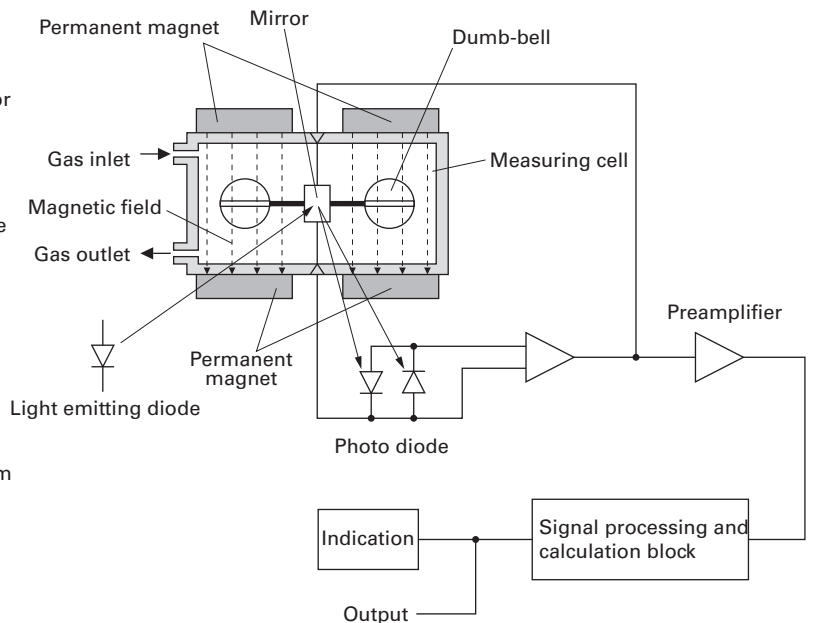

Principle diagram of Sample switching method

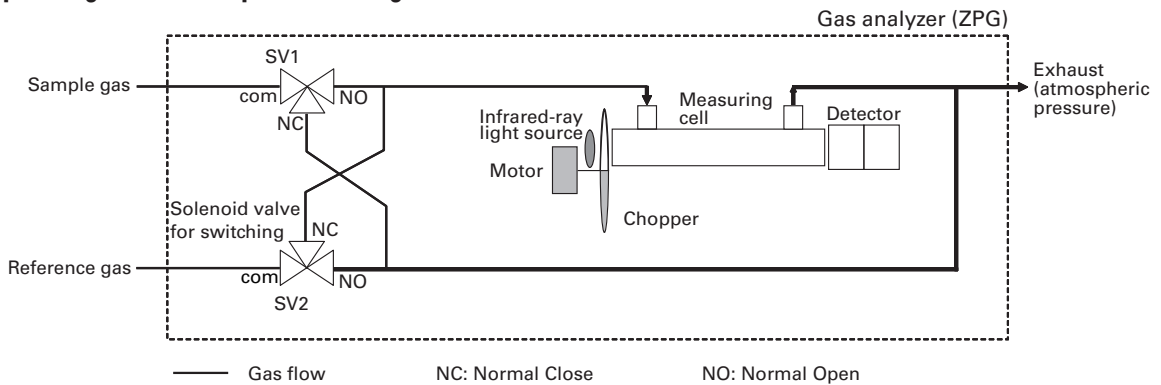

Explanation of the sample switching method

Sample gas and reference gas are introduced alternately and constantly to the sample cell of the analyzer by Solenoid valve for switching flow (SV1,SV2)
 Solenoid valve SV1 and Solenoid valve SV2 are switched by the signal sent from the analyzer. Analyzer measures each sample gas and each reference gas on proper timing and calculates the change of sample gas and reference gas as the concentrate value (= gas concentration of the measurable component) and sends output signal.
 Due to monitoring the change of the sample gas and reference gas all the time, influence of the interference components and zero drift are eliminated.

Examples of sampling system configuration including gas analyzer

*These are typical configurations. As configuration might be different depending on measuring objects. Please consult with us.

1) To measure sample gas without moisture.

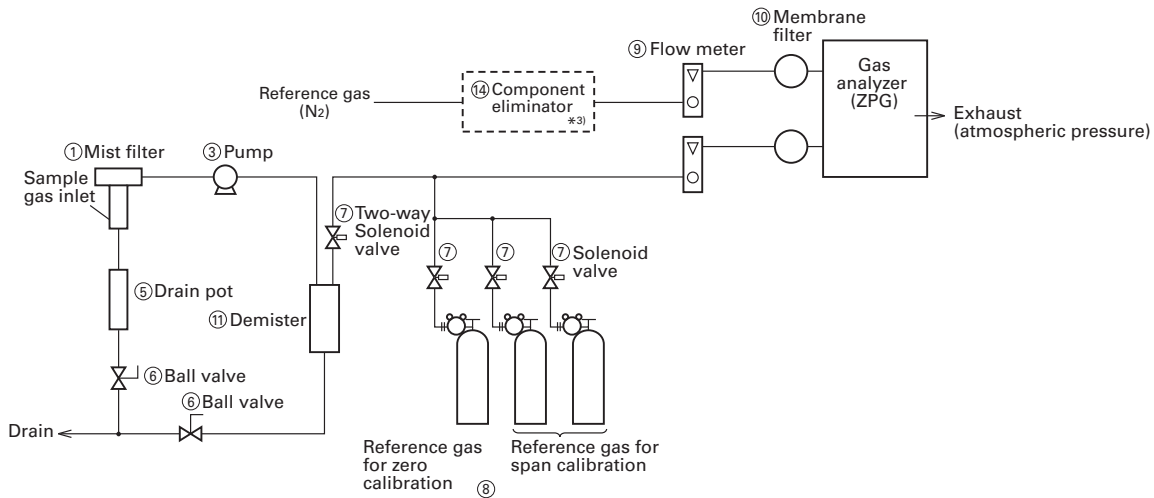

2) To measure high moisture content sample gas, NO, SO₂, or CO (saturation 2°C or more)

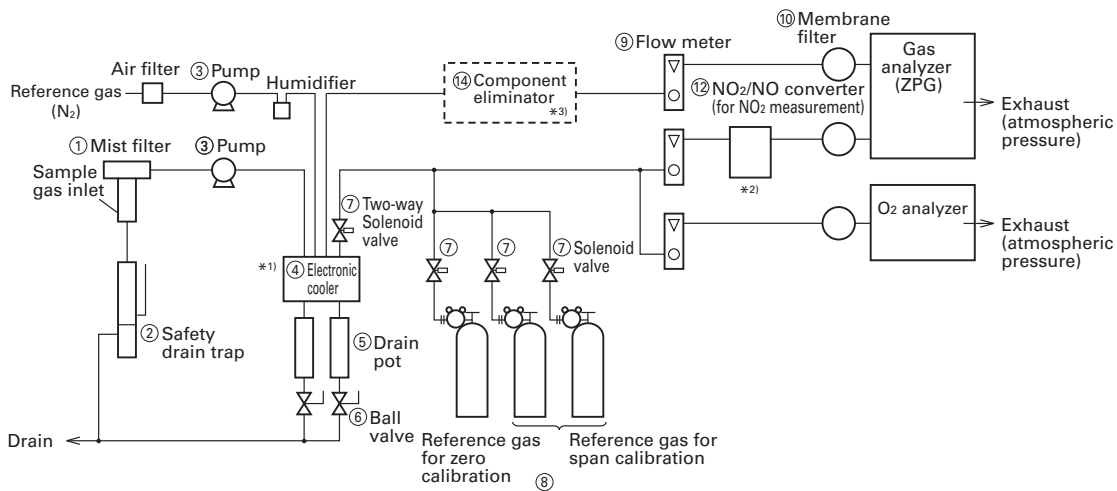

*1) Be sure to remove the moisture to be temperature 5°C or lower from measuring gas by electronic cooler and water concentration should be equalized in reference gas and sample gas.

*2) Be sure to use NO₂/NO converter in case of measuring NO_x.

3) To measure impurity and minute concentration (0-20ppm or less) (Reference gas is not required by this method)

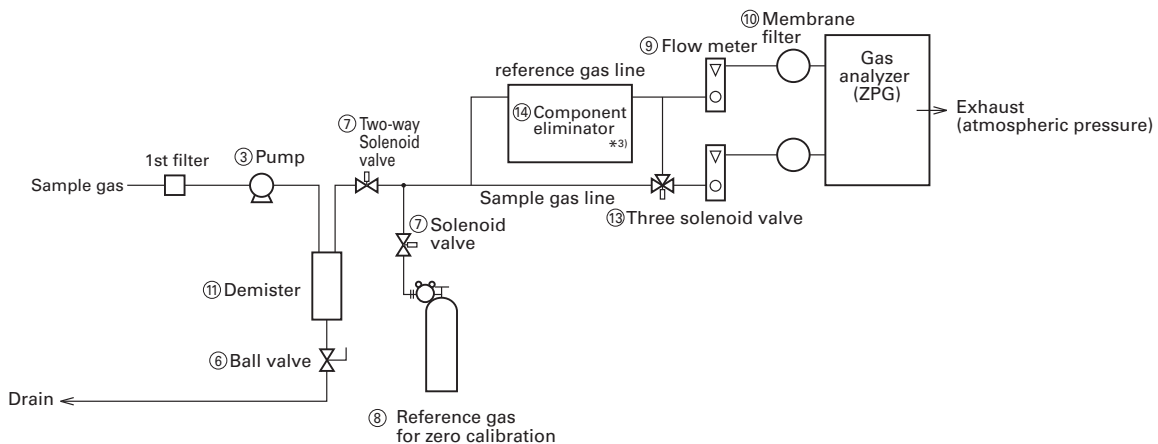

*3) Component eliminator can eliminate only measurable component in the sample gas and use the measurable component as a relative gas.
To measure CO, Use the CO/CO₂ converter (Type: ZDL21). To measure NO, SO₂, CO₂, Use the component eliminator (Type: ZBBB).

List of sampling devices (example)

No.	Device name	Fuji's type	No.	Device name	Fuji's type
①	Mist filter	ZBBK1V03-0	⑨	Flow meter	ZBD42203
②	Safety drain trap	ZBH51603	⑩	Membrane filter	ZBBM2V03-0
③	Pump	ZBG80	⑪	Demister	ZBH35003
④	Electric cooler	ZBC9A004	⑫	NO ₂ /NO converter	ZDL04001
⑤	Drain pot	ZBH13003 (Length 255mm)	⑬	Three-way solenoid valve	
⑥	Ball valve	ZBFB1	⑭	Component eliminator (for NO _x and SO ₂)	ZBBB6V03 or 7V03 *3
⑦	Two-way solenoid valve			Component eliminator (for NO _x and SO ₂)	ZBBB7V03 or 6V03 *3
⑧	Standard gas for calibration	ZBM□Y04-0□ (Codes in□ to be selected depending on application)		Component eliminator (for CO ₂)	ZBBB8V03
				Component eliminator (for CO)	ZDL21001

*3) Refer to SANPLING DEVICE SERIES DATA SHEET(EDS3-1), chapter GAS FILTER(model:ZBB)

Table 1 Channel (Ch) No. and display/output contents comparison table

Code symbol			Display/output contents
6th digit	7th digit	21st digit	
P	Y	Y	Ch1:NO
A	Y	Y	Ch1:SO ₂
D	Y	Y	Ch1:CO ₂
B	Y	Y	Ch1:CO
P	1 to 4	Y	Ch1:NO, Ch2:O ₂
A	1 to 4	Y	Ch1:SO ₂ , Ch2:O ₂
D	1 to 4	Y	Ch1:CO ₂ , Ch2:O ₂
B	1 to 4	Y	Ch1:CO, Ch2:O ₂
P	1 to 4	A	Ch1:NO _x , Ch2:O ₂ , Ch3:corrected NO _x
A	1 to 4	A	Ch1:SO ₂ , Ch2:O ₂ , Ch3:corrected SO ₂
B	1 to 4	A	Ch1:CO, Ch2:O ₂ , Ch3:corrected CO
P	1 to 4	C	Ch1:NO _x , Ch2:O ₂ , Ch3:corrected NO _x , Ch4:corrected NO _x average
A	1 to 4	C	Ch1:SO ₂ , Ch2:O ₂ , Ch3:corrected SO ₂ , Ch4:corrected SO ₂ average
B	1 to 4	C	Ch1:CO, Ch2:O ₂ , Ch3:corrected CO, Ch4:corrected CO average

* When the 21st digit code is A or C, the component of the NO analyzer is displayed as NO_x.

SCOPE OF DELIVERY

- Gas analyzer ... 1 unit
- Replacement fuse (250V, 2A AC, delay type) ... 2 pcs
- Instruction manual ... 1 copy
- Connector for I/O connection ... 1 set
- Power supply cord (standard inlet type 2m) ... 1 pc

ORDERING INFORMATION

1. Code symbols
2. Application and composition of sample gas

CODE SYMBOLS

Digit	Description	note	1	2	3	4	5	6	7	8	9	10	11	12	13	14	15	16	17	18	19	20	21	22	23	24	25	← Digit	
4	<Specification/structure> Horizontal type(Terminal block for power supply) Horizontal type(Power inlet,with lock)	note1	Z	P	G	B	1																						
5	<Mounting> 19 inch rack mounting type EIA conformity(horizontal type)					A	D																						
6	<Measurable component (NDIR)> NO SO ₂ CO ₂ CO Others					P	A	D	B	Z																			
7	<Measurable component (O ₂)> None External O ₂ analyzer External zirconia O ₂ analyzer (ZFK7) Built-in fuel cell O ₂ analyzer Built-in paramagnetic O ₂ analyzer	note2								Y	1	2	3	4															
8	<Revision code>									1																			
9	<Measuring range (NDIR)>1st component, 1st range	note3																											
10	<Measuring range (NDIR)>1st component, 2nd range	note3																											
11	<Unused digit>												Y																
12	<Unused digit>													Y															
13	<Unused digit>														Y														
14	<Unused digit>															Y													
15	<Unused digit>																Y												
16	<Unused digit>																	Y											
17	<Measuring range (O ₂)> None 0-5/10vol% 0-5/25vol% 0-10/25vol% 0-5vol% 0-10vol% 0-25vol% 0-50vol% 0-100vol% Others																	Y	A	B	C								
																		L	M	V	P	R	Z						
18	<Gas connection> Rc1/4 NPT1/4																			1	2								
19	<Output> DC0-1V DC4-20mA DC0-1V + Communication function DC4-20mA + Communication function																			A	B	C	D						
20	<Language/power supply cord> In Japanese, cord rated 125V (PSE) In English, cord rated 125V (UL) In English, cord rated 250V (CEE) In Chinese, cord rated 250V (CCC)	note4 note4 note4 note4																		J	E	U	C						
21	<O ₂ correction and O ₂ correction average output> None O ₂ correction O ₂ correction average O ₂ correction and O ₂ correction average	note5																					Y	A	B	C			
22	<Optional function (DIO)> FAULT A. Cal. H/L Alarm RangeID/Remote range																							Y	A	B	C		
	None ○ ○ ○ ○																							D	E	F	G	H	
	○ ○ ○ ○																												
23	<Pressure compensation> None Pressure compensation																								Y	1			
24	<Unit> ppm, vol% mg/m ³ , g/m ³	note6																									A	B	
25	<Adjustment> For standard(combustion exhaust) Others	note7																										A	Z

RANGE CODE

Range	Code
None	Y
0~5ppm	5
0~10ppm	6
0~20ppm	7
0~25ppm	8
0~30ppm	9
0~50ppm	A
0~100ppm	B

O₂ measurement range

Measurement range	Range code	Fuel cell O ₂ analyzer (built - in)	Paramagnetic O ₂ analyzer (built - in)	Zirconia O ₂ analyzer (external)
0~5/10 vol%	A		○	○
0~5/25 vol%	B		○	○
0~10/25 vol%	C	○	○	○
0~5 vol%	L		○	○
0~10 vol%	M	○	○	○
0~25 vol%	V	○	○	○
0~50 vol%	P		○	
0~100 vol%	R		○	

note1)When "D" is specified at 4th digit, Power supply cord is supplied in the scope of supply. Cord specification should be specified at the 20th digit.

note2)When "1" is specified at 7th digit, O₂ pt analyzer signal has to be set as 0-1V DC linear corresponding to full scale. External zirconia O₂ analyzer and external O₂ analyzer are not included in the scope of supply, and has to be separately ordered.

note3)Select the range code for each range from the range code table shown above. Range of fuel cell O₂ analyzer is 0-10vol% or more.

note4)Select the type of voltage rating, plug type and applicable standard of the power supply cord by 20th digit. Select a power supply cord for using at the location of end-user.

note5)O₂ correction is calculated only for NO, SO₂ and CO.

note6)When "B" is specified at 24th digit, measuring range should be specified by ppm range code. In this case NO,SO₂ and CO measuring range are corresponding range in mg/m³. Please refer to the table shown below for the corresponding range code based on "mg/m³".

note7)When "A" is specified at 25th digit, the analyzer will be adjusted and delivered with the balance gas N₂. When other adjustment is required, please specify "Z". When "Z" is specified, please attach a list of gas composition contained in the measuring gas.

Corresponding mg/m³

Range code	Unit : ppm	Corresponding range in mg/m ³		
		NO	SO ₂	CO
5	0-5ppm	0-6.5mg/m ³	0-14.0mg/m ³	0-6.00mg/m ³
6	0-10ppm	0-13.0mg/m ³	0-28.0mg/m ³	0-12.5mg/m ³
7	0-20ppm	0-26.0mg/m ³	0-57.0mg/m ³	0-25.0mg/m ³
8	0-25ppm	0-32.5mg/m ³	0-70.0mg/m ³	0-30.0mg/m ³
9	0-30ppm	0-40.0mg/m ³	0-85.0mg/m ³	0-37.5mg/m ³
A	0-50ppm	0-65.0mg/m ³	0-140mg/m ³	0-60.0mg/m ³
B	0-100ppm	0-130.0mg/m ³	0-280.0mg/m ³	0-125.0mg/m ³

The conversion formula "ppm" unit into "mg/m³" unit.

NO (mg/m³) = 1.34 × NO (ppm)

SO₂ (mg/m³) = 2.86 × SO₂ (ppm)

CO (mg/m³) = 1.25 × CO (ppm)

Component eliminator (Item to be prepared separately)

<Note before ordering>

Whether or not you need the eliminator, it is depend on using gas as relative gas as follows.

Regarding specification of component eliminator, please refer to Fuji's data sheet DS3-1 "sampling device series for gas analyzer"

1. When you use sample gas as relative gas

Please make sure to use component eliminator to eliminate measurement components from all of measurement components /measurement range of ZPG.

2. When you use Air or N₂ as relative gas

Whether or not you need the eliminator, it is depend on concentration of the component to be measured in relative gas.

If gas concentration to be measured in relative gas is 0.1%FS or less of the range, component eliminator is not needed.

When concentration of the relative gas can not be comprehended correctly, please make sure to use the component eliminator as a general rule.

OUTLINE DIAGRAMS (Unit : mm)

<TOP VIEW>

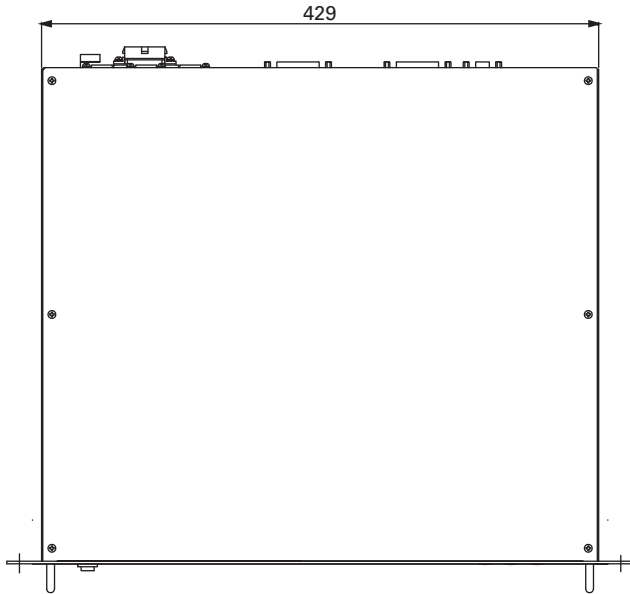

Mounting method

The analyzer weight should be supported at the bottom of the case.

19-inch rack mounting type

<Rack dimensions>

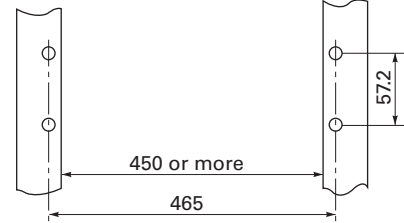

Mounting diagram

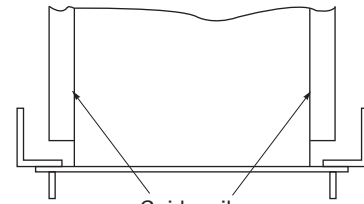

Guide rails

<FRONT VIEW>

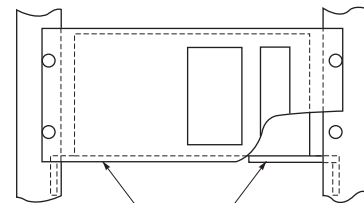
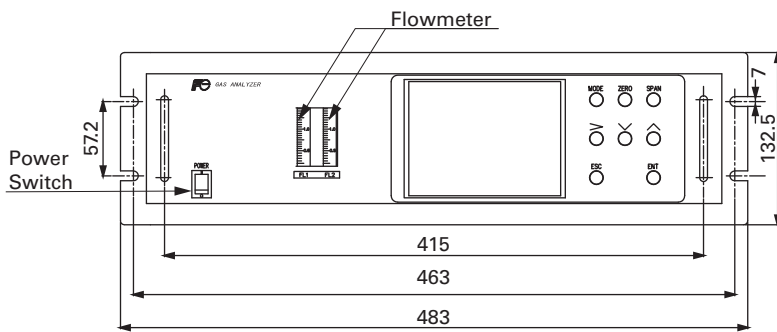

Guide rails

<REAR VIEW>

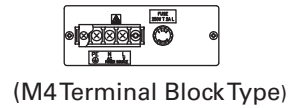
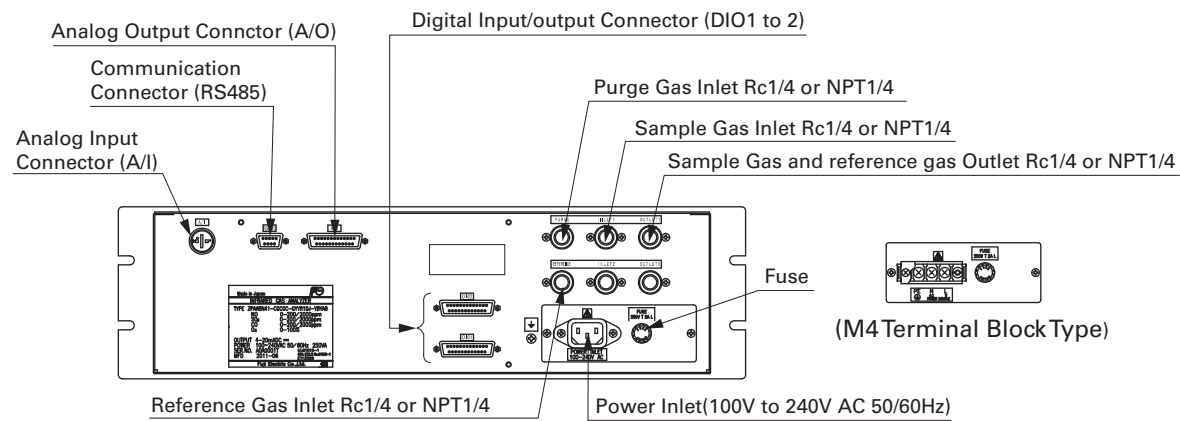

<SIDE VIEW>

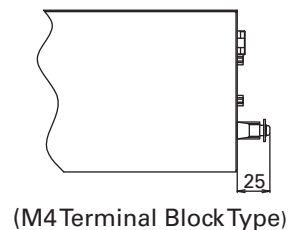
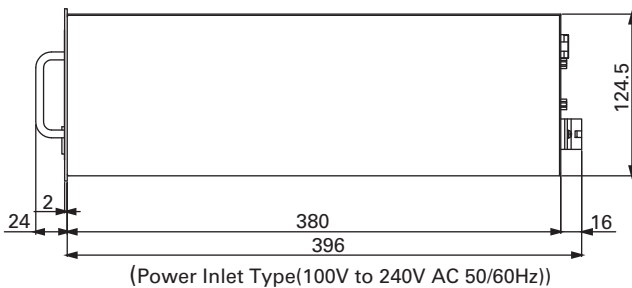

(M4 Terminal Block Type)

EXTERNAL CONNECTION

<Analog output> A/O connector

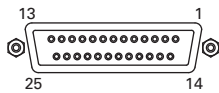

D-sub 25pins female

* In standard, displayed Channel No. and Analog Output No. are same.

<Terminal block>

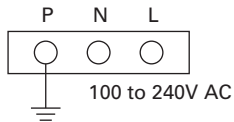

<Power inlet>

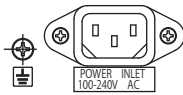

<RS485 communication signal>

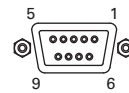

D-sub 9pins female

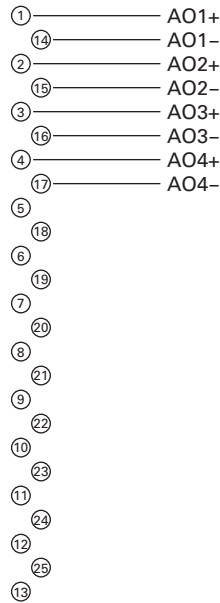
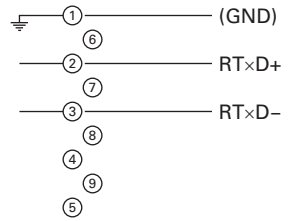

<Analog input> A/I connector (O₂ signal input)

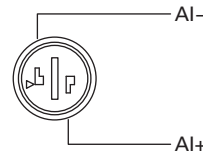

<Digital I/O> DIO 1 to 3 connector (option)

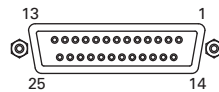

D-sub 25pins female

* DIO 1 to 3 are all as same connector.

Contents of digital input signal

DI1	Remote hold
DI2	Average value reset
DI3	A. cal. start
DI4	A. zero. cal. start
DI5	Remote range Ch1
DI6	Remote range Ch2

Allocation table of digital input signal

22th digit →	A	B	C	D	E	F	G	H	Y
DI1	○	○	○	○	○	○	○	○	
DI2	○	○	○	○	○	○	○	○	
DI3		○			○		○		
DI4		○			○		○		
DI5				○		○	○	○	
DI6				○*		○*	○*	○*	

○ sign shows the function is valid.

* : The function might be invalid depending on the number of measurable components.

For example: DI5 corresponds to 1st component, DI6 corresponds to 2nd components.

Contents of digital output signal

22th digit →	Independent on the number of component	1-component analyzer		2-component analyzer
		B, E	D, F, G, H	B, D, E, F, G, H
DO1	Instrument error	Instrument error	Instrument error	Instrument error
DO2	Calibration error	Calibration error	Calibration error	Calibration error
DO3		A.cal.status	(A.cal.status)	(A.cal.status)
DO4		For zero gas	(For zero gas)	(For zero gas)
DO5		For span gas Ch1	(For span gas Ch1)	(For span gas Ch1)
DO6	(Alarm1)	(Alarm1)	Range identification Ch1	(For span gas Ch2)
DO7	(Alarm2)	(Alarm2)	(Alarm1)	(Range identification Ch1)
DO8				(Range identification Ch2)
DO9				(Alarm1)
DO10				(Alarm2)

The items in the parentheses may not be available depending on the selected type on 22th digit.

The normal open side (NO) of digital output is close when the function is active without range ID.

In case of range ID, normal open (NO) side is close with First range.

The normal close (NC) side is close with Second range.

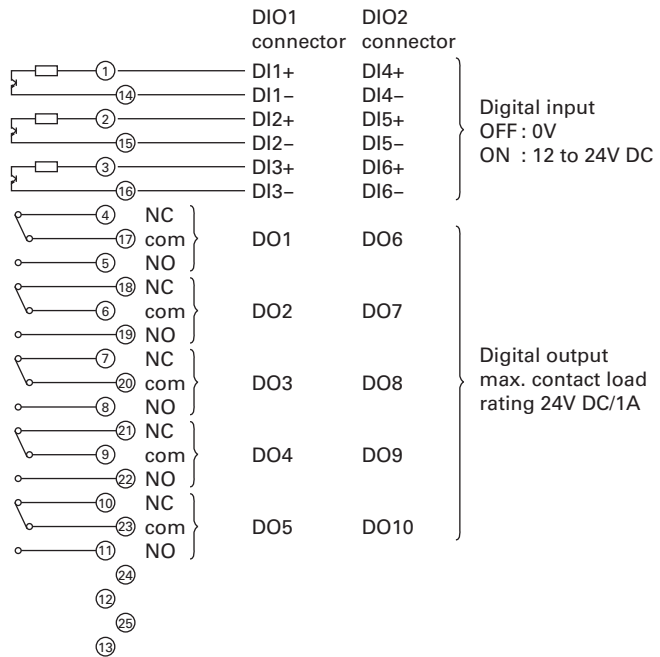

Exclusive Zirconia O₂ analyzer (to be purchased separately)

For O₂ correction, the gas analyzer ZPG can accept linearized 0 to 1V DC signal from the O₂ analyzer calibrated 0 to 25vol% O₂ full scale. If the analyzer is not available, Fuji can supply exclusive Zirconia O₂ analyzer Model ZFK.

Measuring method:

Zirconia system

Measurable component and measuring range:

Measurable component		Range
O ₂	Oxygen	0 to 25vol%

- Repeatability:** Within ± 0.5% of full scale
- Linearity:** Within ± 1% of full scale
- Zero drift:** Within ± 1% of full scale/week
- Span drift:** Within ± 2% of full scale/week
- Response time:** Approx. 20 seconds (for 90% response)
- Measured gas flow rate:** 0.5 ± 0.25L / min

Remark: The Zirconia system, due to its principle, may produce a measuring error due to relative concentration versus the combustible O₂ gas concentration. Also, a corrosive gas (SO₂ of 250 ppm or more, etc.) may affect the life of the analyzer.

Gas inlet/outlet size:

Rc1/4 or NPT1/4

- Power supply:** Rated voltage ; 100 to 115V AC or 200 to 240V AC
Rated frequency ; 50Hz/60Hz
Max. rated power ; 215VA (during power ON)
65VA (during steady-state operation)

Enclosure: Steel casing, for indoor application

Indication: Temperature indication (LED)

Temperature alarm output:

Contact output 1a contact,
Contact capacity 220V, 1A AC (resistive load)

Outer dimensions (H x W x D):

141 x 170 x 190mm

Mass {weight}: Approx. 3kg

Finish color: Munsell 5Y 7/1

CODE SYMBOLS

1 2 3 4 5 6 7 8 9 10 11 12 13													Description	
Z	F	K	7	Y	Y	4	-	Y	0	Y	Y		Measuring method Zirconia method	
7YY														
								9						Power supply 100 to 115V AC 50/60Hz(Standard) 200 to 240V AC 50/60Hz(Standard) 200 to 240V AC 50/60Hz(CE mark)
								B						
								C						
								1						Gas inlet/outlet size Rc 1/4 NPT 1/4
								8						

OUTLINE DIAGRAM (Unit:mm)

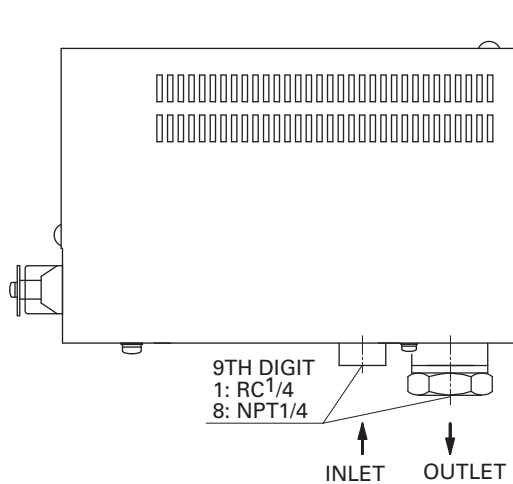
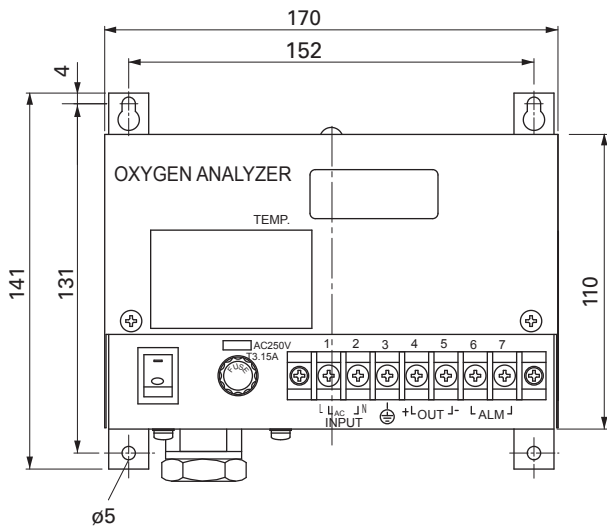

EXTERNAL CONNECTION DIAGRAM

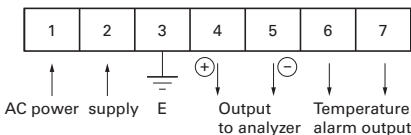

Caution on Safety

*Before using this product, be sure to read its instruction manual in advance.



International Sales Div
Sales Group

Gate City Ohsaki, East Tower, 11-2, Osaki 1-chome,
Shinagawa-ku, Tokyo 141-0032, Japan
http://www.fujielectric.com
Phone: 81-3-5435-7280, 7281 Fax: 81-3-5435-7425
http://www.fjelectric.com/products/instruments/